



ST. VINCENT AND THE GRENADINES

MARITIME ADMINISTRATION

CIRCULAR N° SOL 046- Rev. 1

REVISED GUIDELINES FOR THE PREPARATION OF THE CARGO SECURING MANUAL MSC.1/Circ.1352 AND MSC.1/Circ.1353/Rev.1

TO: SHIPOWNERS, SHIPS' OPERATORS AND
MANAGERS, SHIP BUILDERS, MASTERS,
RECOGNIZED ORGANIZATIONS

APPLICABLE TO: ALL SHIPS WHICH CARRY, LOAD OR DISCHARGE
CARGO UNITS AND CARGO TRANSPORT UNITS

EFFECTIVE AS FROM: Date of this Circular

27th July 2015

General

In accordance with regulations VI/5 and VII/5 of SOLAS 1974, as amended, cargo units and cargo transport units should be loaded, stowed and secured throughout the voyage in accordance with the Cargo Securing Manual approved by this Administration, which should be drawn up to a standard at least equivalent to the Guidelines developed by the Organization. Recognized Organizations are authorized to review and approve Cargo Securing Manuals on behalf of this Administration.

The Maritime Safety Committee, at its 87th Session in May 2010, approved the amendments to the Code of Safe Practice for Cargo Stowage and Securing (CSS Code) for circulation as MSC.1/Circ.1352. The amendments includes Guidance on Providing Safe Working Conditions for Securing of Containers on Deck as a new annex 14 which is in the CSS Code.

The IMO's Revised Guidelines for the Preparation of the Cargo Securing Manual (contained in Circular MSC.1/Circ.1353/Rev.1) introduced new requirements for the contents of the Cargo Securing and a new Chapter 5 Cargo Safe Access Plan.

Existing ships whose keel was laid before 1st January, 2015

If the existing Cargo Securing Manual has been approved previously in accordance with MSC/Circ.385 or MSC/Circ.745, then it already complies with the new requirements provided the language requirement (MSC.1/Circ.1353/Rev.1, Annex, Para 1.2) is fulfilled. It is not necessary for the Cargo Securing Manual to be re-approved. The requirements of Chapter 5 (Cargo Safe Access Plan) do not apply to existing ships.

New ships ~~with~~ whose keel was laid on or after 1st January, 2015

The Cargo Securing Manual should fully comply with MSC.1/Circ.1353/Rev.1, including the requirements of the new Chapter 5 (Cargo Safe Access Plan).

All parties concerned should take into account the above amendments.

Circulars MSC.1/Circ.1352 and MSC.1/Circ.1353/Rev.1 are annexed to this Circular.

4 ALBERT EMBANKMENT
LONDON SE1 7SR
Telephone: +44 (0)20 7735 7611 Fax: +44 (0)20 7587 3210

MSC.1/Circ.1352/Rev.1
15 December 2014

**AMENDMENTS TO THE CODE OF SAFE PRACTICE FOR CARGO STOWAGE
AND SECURING (CSS CODE)**

1 The Maritime Safety Committee (the Committee), at its ninety-fourth session (17 to 21 November 2014), considered and approved amendments to the Code of Safe Practice for Cargo Stowage and Securing (CSS Code), set out in the annex. The present circular also incorporates the amendments approved by the Committee, at its eighty-seventh session (12 to 21 May 2010) (MSC 87/26, paragraph 10.4 refers).

2 Member Governments are invited to bring the annexed Amendments to the CSS Code to the attention of shipowners, ship operators, shipmasters and crews and all other parties concerned and, in particular, encourage shipowners and terminal operators to:

- .1 apply the annexed amendments in its entirety for containerhips*, the keels of which were laid or which are at a similar stage of construction on or after 1 January 2015;
- .2 apply sections 4.4 (Training and familiarization), 7.1 (Introduction), 7.3 (Maintenance) and section 8 (Specialized container safety design) to existing containerhips*, the keels of which were laid or which are at a similar stage of construction before 1 January 2015; and
- .3 apply the principles of this guidance contained in sections 6 (Design) and 7.2 (Operational procedures) to existing containerhips* as far as practical by the flag State Administration with the understanding that existing ships would not be required to be enlarged or undergo other major structural modifications as determined.

3 This circular revokes MSC.1/Circ.1352 issued on 30 June 2010 and any reference to MSC.1/Circ.1352 should be read as reference to the present circular.

* Reference to containerhips means dedicated containerhips and those parts of other ships for which arrangements are specifically designed and fitted for the purpose of carrying containers on deck.

ANNEX

AMENDMENTS TO THE CODE OF SAFE PRACTICE FOR CARGO STOWAGE AND SECURING (CSS CODE)

- 1 The following new annex 14 is inserted after the existing annex 13:

"ANNEX 14

GUIDANCE ON PROVIDING SAFE WORKING CONDITIONS FOR SECURING OF CONTAINERS ON DECK

1 AIM

To ensure that persons engaged in carrying out container securing operations on deck have safe working conditions and, in particular safe access, appropriate securing equipment and safe places of work. These guidelines should be taken into account at the design stage when securing systems are devised. These guidelines provide shipowners, ship builders, classification societies, Administrations and ship designers with guidance on producing or authorizing a Cargo Safe Access Plan (CSAP).

2 SCOPE

Ships which are specifically designed and fitted for the purpose of carrying containers on deck.

3 DEFINITIONS

3.1 *Administration* means the Government of the State whose flag the ship is entitled to fly.

3.2 *Containership* means dedicated containerships and those parts of other ships for which arrangements are specifically designed and fitted for the purpose of carrying containers on deck.

3.3 *Fencing* is a generic term for guardrails, safety rails, safety barriers and similar structures that provide protection against the falls of persons.

3.4 *Lashing positions* include positions:

- .1 in between container stows on hatch covers;
- .2 at the end of hatches;
- .3 on outboard lashing stanchions/pedestals;
- .4 outboard lashing positions on hatch covers; and
- .5 any other position where people work with container securing.

3.5 *SATLs* are semi-automatic twistlocks.

3.6 *Securing* includes lashing and unlashings.

3.7 *Stringers* are the uprights or sides of a ladder.

3.8 *Turnbuckles and lashing rods** include similar cargo securing devices.

4 GENERAL

4.1 Introduction

4.1.1 Injuries to dockworkers on board visiting ships account for the majority of accidents that occur within container ports, with the most common activity that involves such injuries being the lashing/unlashing of deck containers. Ships' crew engaged in securing operations face similar dangers.

4.1.2 During the design and construction of containerships the provision of a safe place of work for lashing personnel is essential.

4.1.3 Container shipowners and designers are reminded of the dangers associated with container securing operations and urged to develop and use container securing systems which are safe by design. The aim should be to eliminate or at least minimize the need for:

- .1 container top work;
- .2 work in other equally hazardous locations; and
- .3 the use of heavy and difficult to handle securing equipment.

4.1.4 It should be borne in mind that providing safe working conditions for securing containers deals with matters relating to design, operation, and maintenance, and that the problems on large containerships are not the same as on smaller ones.

4.2 Revised recommendations on safety of personnel during container securing operations (MSC.1/Circ.1263)

Shipowners, ship designers and Administrations should take into account the recommendations on safe design of securing arrangements contained in these guidelines, and in the Recommendations on safety of personnel during container securing operations (MSC.1/Circ.1263).

4.3 Cargo Safe Access Plan (CSAP)

4.3.1 The *Guidelines for the preparation of the Cargo Securing Manual* (MSC/Circ.745) requires ships which are specifically designed and fitted for the purpose of carrying containers to have an approved Cargo Safe Access Plan (CSAP) on board, for all areas where containers are secured.

4.3.2 Stakeholders, including, but not limited to shipowners, ship designers, ship builders, administrations, classification societies and lashing equipment manufacturers, should be involved at an early stage in the design of securing arrangements on containerships and in the development of the CSAP.

4.3.3 The CSAP should be developed at the design stage in accordance with chapter 5 of the annex to MSC.1/Circ.1353.

4.3.4 Designers should incorporate the recommendations of this annex into the CSAP so that safe working conditions can be maintained during all anticipated configurations of container stowage.

* Refer to standard ISO 3874, Annex D Lashing rod systems and tensioning devices.

4.4 Training and familiarization

4.4.1 Personnel engaged in cargo securing operations should be trained in the lashing and unlashings of containers as necessary to carry out their duties in a safe manner. This should include the different types of lashing equipment that are expected to be used.

4.4.2 Personnel engaged in cargo securing operations should be trained in the identification and handling of bad order or defective securing gear in accordance with each ship's procedures to ensure damaged gear is segregated for repair and maintenance or disposal.

4.4.3 Personnel engaged in cargo securing operations should be trained to develop the knowledge and mental and physical manual handling skills that they require to do their job safely and efficiently, and to develop general safety awareness to recognize and avoid potential dangers.

4.4.4 Personnel should be trained in safe systems of work. Where personnel are involved in working at heights, they should be trained in the use of relevant equipment. Where practical, the use of fall protection equipment should take precedence over fall arrest systems.

4.4.5 Personnel who are required to handle thermal cables and/or connect and disconnect temperature control units should be given training in recognizing defective cables, receptacles and plugs.

4.4.6 Personnel engaged in containership cargo operations should be familiarized with the ship's unique characteristics and potential hazards arising from such operations necessary to carry out their duties.

5 RESPONSIBILITIES OF INVOLVED PARTIES

5.1 Administrations should ensure that:

- .1 lashing plans contained within the approved Cargo Securing Manual are compatible with the current design of the ship and the intended container securing method is both safe and physically possible;
- .2 the Cargo Securing Manual, lashing plans and the CSAP are kept up to date; and
- .3 lashing plans and the CSAP are compatible with the design of the vessel and the equipment available.

5.2 Shipowners and operators should ensure that:

- .1 portable cargo securing devices are certified and assigned with a maximum securing load (MSL). The MSL should be documented in the cargo securing manual as required by the CSS Code;
- .2 the operational recommendations of this annex are complied with;
- .3 correction, changes or amendments of the Cargo Securing Manual, lashing plans and the Cargo Safe Access Plan (CSAP) should be promptly sent to the competent authority for approval; and

- .4 only compatible and certified equipment in safe condition is used.
- 5.3 Designers should follow design recommendations of these guidelines.
- 5.4 Shipbuilders should follow design recommendations of these guidelines.
- 5.5 Containership terminal operators should ensure that the recommendations of relevant parts of this annex are complied with.

6 DESIGN

6.1 General design considerations

6.1.1 Risk assessment

6.1.1.1 Risk assessments should be performed at the design stage taking into account the recommendations of this annex to ensure that securing operations can be safely carried out in all anticipated container configurations. This assessment should be conducted with a view toward developing the Cargo Safe Access Plan (CSAP). Hazards to be assessed should include but not be limited to:

- .1 slips, trips and falls;
- .2 falls from height;
- .3 injuries whilst manually handling lashing gear;
- .4 being struck by falling lashing gear or other objects;
- .5 potential damage due to container operations. High-risk areas should be identified in order to develop appropriate protection or other methods of preventing significant damage;
- .6 adjacent electrical risks (temperature controlled unit cable connections, etc.);
- .7 the adequacy of the access to all areas that is necessary to safely perform container securing operations;
- .8 ergonomics (e.g. size and weight of equipment) of handling lashing equipment; and
- .9 implications of lashing 9'6" high, or higher, containers and mixed stows of 40' and 45' containers.

6.1.1.2 Shipbuilders should collaborate with designers of securing equipment in conducting risk assessments and ensure that the following basic criteria are adhered to when building containerships.

6.1.2 Ship designers should ensure that container securing operations performed in outer positions can be accomplished safely. As a minimum, a platform should be provided on which to work safely. This platform should have fencing to prevent workers falling off it.

6.1.3 The space provided between the containers stows for workers to carry out lashing operations should provide:

- .1 a firm and level working surface;
- .2 a working area, excluding lashings in place, to provide a clear sight of twist lock handles and allow for the manipulation of lashing gear;
- .3 sufficient spaces to permit the lashing gear and other equipment to be stowed without causing a tripping hazard;
- .4 sufficient spaces between the fixing points of the lashing bars on deck, or on the hatch covers, to tighten the turnbuckles;
- .5 access in the form of ladders on hatch coamings;
- .6 safe access to lashing platforms;
- .7 protective fencing on lashing platforms; and
- .8 adequate lighting in line with these guidelines.

6.1.4 Ship designers should aim to eliminate the need to access and work on the tops of deck stows.

6.1.5 Platforms should be designed to provide a clear work area, unencumbered by deck piping and other obstructions and take into consideration:

- .1 containers must be capable of being stowed within safe reach of the workers using the platform; and
- .2 the work area size and the size of the securing components used.

6.2 Provisions for safe access

6.2.1 General provisions

6.2.1.1 The minimum clearance for transit areas should be at least 2 m high and 600 mm wide (see table in supplement, dimensions B, J, K1).

6.2.1.2 All relevant deck surfaces used for movement about the ship and all passageways and stairs should have non-slip surfaces.

6.2.1.3 Where necessary for safety, walkways on deck should be delineated by painted lines or otherwise marked by pictorial signs.

6.2.1.4 All protrusions in access ways, such as cleats, ribs and brackets that may give rise to a trip hazard should be highlighted in a contrasting colour.

6.2.2 Lashing position design (platforms, bridges and other lashing positions)

6.2.2.1 Lashing positions should be designed to eliminate the use of three high lashing bars and be positioned in close proximity to lashing equipment stowage areas. Lashing positions should be designed to provide a clear work area which is unencumbered by deck piping and other obstructions and take into consideration:

- .1 the need for containers to be stowed within safe reach of the personnel using the lashing position so that the horizontal operating distance from the securing point to the container does not exceed 1,100 mm and not less than 220 mm for lashing bridges and 130 mm for other positions (see table in supplement, dimensions C1, C2, C3);
- .2 the size of the working area and the movement of lashing personnel; and
- .3 the length and weight of lashing gear and securing components used.

6.2.2.2 The width of the lashing positions should preferably be 1,000 mm, but not less than 750 mm (see table in supplement, dimensions A, GL, GT, I, K).

6.2.2.3 The width of permanent lashing bridges should be:

- .1 750 mm between top rails of fencing (see table in supplement, dimension F); and
- .2 a clear minimum of 600 mm between storage racks, lashing cleats and any other obstruction (see table in supplement, dimension F1).

6.2.2.4 Platforms on the end of hatches and outboard lashing stations should preferably be at the same level as the top of the hatch covers.

6.2.2.5 Toe boards (or kick plates) should be provided around the sides of elevated lashing bridges and platforms to prevent securing equipment from falling and injuring people. Toe boards should preferably be 150 mm high, however, where this is not possible they should be at least 100 mm high.

6.2.2.6 Any openings in the lashing positions through which people can fall should be possible to be closed.

6.2.2.7 Lashing positions should not contain obstructions, such as storage bins or guides to reposition hatch covers.

6.2.2.8 Lashing positions which contain removable sections should be capable of being temporarily secured.

6.2.3 Fencing design

6.2.3.1 Bridges and platforms, where appropriate, should be fenced. As a minimum, fencing design should take into consideration:

- .1 the strength and height of the rails should be designed to prevent workers from falling;

- .2 flexibility in positioning the fencing of gaps. A horizontal unfenced gap should not be greater than 300 mm;
- .3 provisions for locking and removal of fencing as operational situations change based on stowage anticipated for that area;
- .4 damage to fencing and how to prevent failure due to that damage; and
- .5 adequate strength of any temporary fittings. These should be capable of being safely and securely installed.

6.2.3.2 The top rail of fencing should be 1 m high from the base, with two intermediate rails. The opening below the lowest course of the guard rails should not exceed 230 mm. The other courses should be not more than 380 mm apart.

6.2.3.3 Where possible fences and handrails should be highlighted with a contrasting colour to the background.

6.2.3.4 Athwartships cargo securing walkways should be protected by adequate fencing if an unguarded edge exists when the hatch cover is removed.

6.2.4 Ladder and manhole design

6.2.4.1 Where a fixed ladder gives access to the outside of a lashing position, the stringers should be connected at their extremities to the guardrails of the lashing position, irrespective of whether the ladder is sloping or vertical.

6.2.4.2 Where a fixed ladder gives access to a lashing position through an opening in the platform, the opening shall be protected with either a fixed grate with a lock back mechanism, which can be closed after access, or fencing. Grabrails should be provided to ensure safe access through the opening.

6.2.4.3 Where a fixed ladder gives access to a lashing position from the outside of the platform, the stringers of the ladder should be opened above the platform level to give a clear width of 700 to 750 mm to enable a person to pass through the stringers.

6.2.4.4 A fixed ladder should not slope at an angle greater than 25° from the vertical. Where the slope of a ladder exceeds 15° from the vertical, the ladder should be provided with suitable handrails not less than 540 mm apart, measured horizontally.

6.2.4.5 A fixed vertical ladder of a height exceeding 3 m, and any fixed vertical ladder, from which a person may fall into a hold, should be fitted with guard hoops, which should be constructed in accordance with paragraphs 6.2.4.6 and 6.2.4.7.

6.2.4.6 The ladder hoops should be uniformly spaced at intervals not exceeding 900 mm and should have a clearance of 750 mm from the rung to the back of the hoop and be connected by longitudinal strips secured to the inside of the hoops, each equally spaced round the circumference of the hoop.

6.2.4.7 The stringers should be carried above the floor level of the platform by at least 1 m and the ends of the stringers should be given lateral support and the top step or rung should be level with the floor of the platform unless the steps or rungs are fitted to the ends of the stringers.

6.2.4.8 As far as practicable, access ladders and walkways, and work platforms should be designed so that workers do not have to climb over piping or work in areas with permanent obstructions.

6.2.4.9 There should be no unprotected openings in any part of the workplace. Access opening must be protected with handrails or access covers that can be locked back during access.

6.2.4.10 As far as practicable, manholes should not be situated in transit areas, however, if they are, proper fencing should protect them.

6.2.4.11 Access ladders and manholes should be large enough for persons to safely enter and leave.

6.2.4.12 A foothold at least 150 mm deep should be provided.

6.2.4.13 Handholds should be provided at the top of the ladder to enable safe access to the platform to be gained.

6.2.4.14 Manhole openings that may present a fall hazard should be highlighted in contrasting colour around the rim of the opening.

6.2.4.15 Manhole openings at different levels of the lashing bridge should not be located directly below one another, as far as practicable.

6.3 Lashing systems

6.3.1 General provisions

Lashing systems, including tensioning devices, should:

- .1 conform to international standards*, where applicable;
- .2 be compatible with the planned container stowages;
- .3 be compatible with the physical ability of persons to safely hold, deploy and use such equipment;
- .4 be uniform and compatible, e.g. twistlocks and lashing rod heads should not interfere with each other;
- .5 be subject to a periodic inspection and maintenance regime. Non-conforming items should be segregated for repair or disposal; and
- .6 be according to the CSM.

6.3.2 Twistlock design

6.3.2.1 Shipowners should ensure that the number of different types of twistlocks provided for cargo securing is kept to a minimum and clear instructions are provided for their operation. The use of too many different types of twistlocks may lead to confusion as to whether the twistlocks are locked.

* Refer to standard ISO 3874 – The Handling and Securing of Type 1 Freight Containers, annex A-D.

6.3.2.2 The design of twistlocks should ensure the following:

- .1 positive locking with easy up and down side identification;
- .2 dislodging from corner fitting is not possible even when grazing a surface;
- .3 access and visibility of the unlocking device is effective in operational situations;
- .4 unlocked positions are easily identifiable and do not relock inadvertently due to jolting or vibration; and
- .5 unlocking poles are as light as possible, of a simple design for ease of use.

6.3.2.3 Where it is not feasible to entirely eliminate working on the tops of container stows, the twistlock designs used should minimize the need for such working, e.g. use of SATLs, fully automatic twistlocks or similar design.

6.3.3 Lashing rod design

6.3.3.1 The design of containership securing systems should take into account the practical abilities of the workers to lift, reach, hold, control and connect the components called for in all situations anticipated in the cargo securing plan.

6.3.3.2 The maximum length of a lashing rod should be sufficient to reach the bottom corner fitting of a container on top of two high cube containers and be used in accordance with the instructions provided by the manufacturers.

6.3.3.3 The weight of lashing rods should be minimized as low as possible consistent with the necessary mechanical strength.

6.3.3.4 The head of the lashing rod that is inserted in the corner fitting should be designed with a pivot/hinge or other appropriate device so that the rod does not come out of the corner fitting accidentally.

6.3.3.5 The rod's length in conjunction with the length and design of the turnbuckle should be such that the need of extensions is eliminated when lashing high cube (9'6") containers.

6.3.3.6 Lightweight rods should be provided where special tools are needed to lash high cube containers.

6.3.4 Turnbuckle design

6.3.4.1 Turnbuckle end fittings should be designed to harmonize with the design of lashing rods.

6.3.4.2 Turnbuckles should be designed to minimize the work in operating them.

6.3.4.3 Anchor points for turnbuckles should be positioned to provide safe handling and to prevent the bending of rods.

6.3.4.4 To prevent hand injury during tightening or loosening motions, there should be a minimum distance of 70 mm between turnbuckles.

6.3.4.5 The turnbuckle should incorporate a locking mechanism which will ensure that the lashing does not work loose during the voyage.

6.3.4.6 The weight of turnbuckles should be minimized as low as possible consistent with the necessary mechanical strength.

6.3.5 Storage bins and lashing equipment stowage design

6.3.5.1 Bins or stowage places for lashing materials should be provided.

6.3.5.2 All lashing gear should be stowed as close to its intended place of use as possible.

6.3.5.3 The stowage of securing devices should be arranged so they can easily be retrieved from their stowage location.

6.3.5.4 Bins for faulty or damaged gear should also be provided and appropriately marked.

6.3.5.5 Bins should be of sufficient strength.

6.3.5.6 Bins and their carriers should be designed to be lifted off the vessel and restowed.

6.4 Lighting design

A lighting plan should be developed to provide for:

- .1 the proper illumination[†] of access ways, not less than 10 lux (1 foot candle)^{*}, taking into account the shadows created by containers that may be stowed in the area to be lit, for example different length containers in or over the work area;
- .2 a separate fixed or temporary (where necessary) lighting system for each working space between the container bays, which is bright enough, not less than 50 lux (5 foot candle)^{*}, for the work to be done, but minimizes glare to the deck workers;
- .3 such illumination should, where possible, be designed as a permanent installation and adequately guarded against breakage; and
- .4 the illumination[†] intensity should take into consideration the distance to the uppermost reaches where cargo securing equipment is utilized.

[†] For the upper tier of a lashing bridge, lights at the port and starboard extremities are generally adequate.

^{*} Refer to Safety and Health in Ports, ILO Code of Practice, section 7.1.5.

7 OPERATIONAL AND MAINTENANCE PROCEDURES

7.1 Introduction

7.1.1 Procedures for safe lashing and securing operations should be included in the ship's Safety Management System as part of the ISM Code documentation.

7.1.2 Upon arrival of the ship, a safety assessment of the lashing positions and the access to those positions should be made before securing work commences.

7.2 Operational procedures

7.2.1 *Container deck working*

7.2.1.1 Transit areas should be safe and clear of cargo and all equipment.

7.2.1.2 Openings that are necessary for the operation of the ship, which are not protected by fencing, should be closed during cargo securing work. Any necessarily unprotected openings in work platforms (i.e. those with a potential fall of less than 2 m), and gaps and apertures on deck should be properly highlighted.

7.2.1.3 The use of fencing is essential to prevent falls. When openings in safety barriers are necessary to allow container crane movements, particularly with derricking cranes, removable fencing should be used whenever possible.

7.2.1.4 It should be taken into account that, when lifting lashing bars that can weigh between 11 and 21 kg and turnbuckles between 16 and 23 kg, there may be a risk of injury and severe illness as a result of physical strain if handled above shoulder height with the arms extended. It is therefore recommended that personnel work in pairs to reduce the individual workload in securing the lashing gear.

7.2.1.5 The company involved with cargo operation should anticipate, identify, evaluate and control hazards and take appropriate measures to eliminate or minimize potential hazards to prevent in particular with harmful lumbar spinal damage and severe illness as a result of physical strain.

7.2.1.6 Personnel engaged in containership cargo operations should wear appropriate Personnel Protective Equipment (PPE) whilst carrying out lashing operations. The PPE should be provided by the company.

7.2.1.7 Manual twistlocks should only be used where safe access is provided.

7.2.1.8 Containers should not be stowed in spaces configured for larger sized containers unless they can be secured under safe working conditions.

7.2.2 *Container top working*

7.2.2.1 When work on container tops cannot be avoided, safe means of access should be provided by the container cargo operation terminal, unless the ship has appropriate means of access in accordance with the CSAP.

7.2.2.2 Recommended practice involves the use of a safety cage lifted by a spreader to minimize the risk to personnel.

7.2.2.3 A safe method of work should be developed and implemented to ensure the safety of lashers when on the top of container stows on deck. Where practical, the use of fall prevention equipment should take precedence over fall arrest equipment.

7.2.3 Failure to provide safe lashing stations on board/carry out lashing by port workers

7.2.3.1 Where there are lashing and unlashings locations on board ship where no fall protection, such as adequate handrails are provided, and no other safe method can be found, the containers should not be lashed or unlashings and the situation should be reported to shoreside supervisor and the master or deck officer immediately.

7.2.3.2 If protective systems cannot be designed to provide safe protected access and lashing work positions, in all cargo configurations then cargo should not be stowed in that location. Neither crew nor shore workers should be subjected to hazardous working conditions in the normal course of securing cargo.

7.3 Maintenance

7.3.1 In line with section 2.3 (Inspection and maintenance schemes) of the *Revised guidelines for the preparation of the cargo securing manual* (MSC.1/Circ.1353) all ships should maintain a record book, which should contain the procedures for accepting, maintaining and repairing or rejecting of cargo securing devices. The record book should also contain a record of inspections.

7.3.2 Lighting should be properly maintained.

7.3.3 Walkways, ladders, stairways and fencings should be subject to a periodic maintenance programme which will reduce/prevent corrosion and prevent subsequent collapse.

7.3.4 Corroded walkways, ladders, stairways and fencings should be repaired or replaced as soon as practicable. The repairs should be effected immediately if the corrosion could prevent safe operations.

7.3.5 It should be borne in mind that turnbuckles covered with grease are difficult to handle when tightening.

7.3.6 Storage bins and their carriers should be maintained in a safe condition.

8 SPECIALIZED CONTAINER SAFETY DESIGN

8.1 Temperature controlled unit power outlets should provide a safe, watertight electrical connection.

8.2 Temperature controlled unit power outlets should feature a heavy duty, interlocked and circuit breaker protected electrical power outlet. This should ensure the outlet can not be switched "live" until a plug is fully engaged and the actuator rod is pushed to the "On" position. Pulling the actuator rod to the "Off" position should manually de-energize the circuit.

8.3 The temperature controlled unit power circuit should de-energize automatically if the plug is accidentally withdrawn while in the "On" position. Also, the interlock mechanism should break the circuit while the pin and sleeve contacts are still engaged.

This provides total operator safety and protection against shock hazard while eliminating arcing damage to the plug and receptacle.

8.4 Temperature controlled unit power outlets should be designed to ensure that the worker is not standing directly in front of the socket when switching takes place.

8.5 The positioning of the temperature controlled unit feed outlets should not be such that the flexible cabling needs to be laid out in such a way as to cause a tripping hazard.

8.6 Stevedores or ship's crew who are required to handle temperature controlled unit cables and/or connect and disconnect reefer units should be given training in recognizing defective wires and plugs.

8.7 Means or provisions should be provided to lay the temperature controlled unit cables in and protect them from lashing equipment falling on them during lashing operations.

8.8 Defective or inoperative temperature controlled unit plugs/electrical banks should be identified and confirmed as "locked out/tagged out" by the vessel.

9 REFERENCES

ILO Code of Practice – Safety and Health in Ports

ILO Convention 152 – Occupational Safety and Health in Dock Work

ISO Standard 3874 – The Handling and Securing of Type 1 Freight Containers

International Convention on Load Lines, 1966, as modified by the 1988 LL Protocol

Revised Recommendation on safety of personnel during container securing operations (MSC.1/Circ.1263)

Revised Guidelines for the preparation of the Cargo Securing Manual (MSC.1/Circ.1353/Rev.1).

SUPPLEMENT

CONTAINER SECURING DIMENSIONS

Dimension (see Figures)	Description	Requirement (mm)
A	Width of work area between container stacks(see figure 1)	750 minimum
B	Distance between lashing plates on deck or on hatch covers (see figure 1)	600 minimum
C1	Distance from lashing bridge fencing to container stack (see figure 2)	1100 maximum
C2	Distance from lashing plate to container stack (lashing bridge) (see figure 2)	220 minimum
C3	Distance from lashing plate to container stack (elsewhere) (see figures 1 and 4)	130 minimum
F	Width of lashing bridge between top rails of fencing (see figure 2)	750 minimum
F1	Width of lashing bridge between storage racks, lashing cleats and any other obstruction (see figure 2)	600 minimum
GL	Width of working platform for outboard lashing – fore/aft (see figure 3)	750 minimum
GT	Width of working platform for outboard lashing – transverse (see figure 3)	750 minimum
I	Width of work platform at end of hatch cover or adjacent to superstructure (see figure 4)	750 minimum
J	Distance from edge of hatch cover to fencing (see figure 4)	600 minimum
K	Width of lashing bridge between top rails of fencing (see figure 2)	750 minimum
K1	Width of lashing bridge between the pillars of the lashing bridge (see figure 2)	600 minimum
NOTES		
B	- Measured between the centres of the lashing plates.	
C1	- Measured from inside of fencing.	
C2, C3	- Measured from centre of lashing plate to end of container.	
F, K	- Measured to inside of fencing.	
GL	- Measured from end of container to inside of fencing.	
GT	- Measured to inside of fencing.	
I	- Measured to inside of fencing.	
J	- Measured to inside of fencing.	

Figure 1

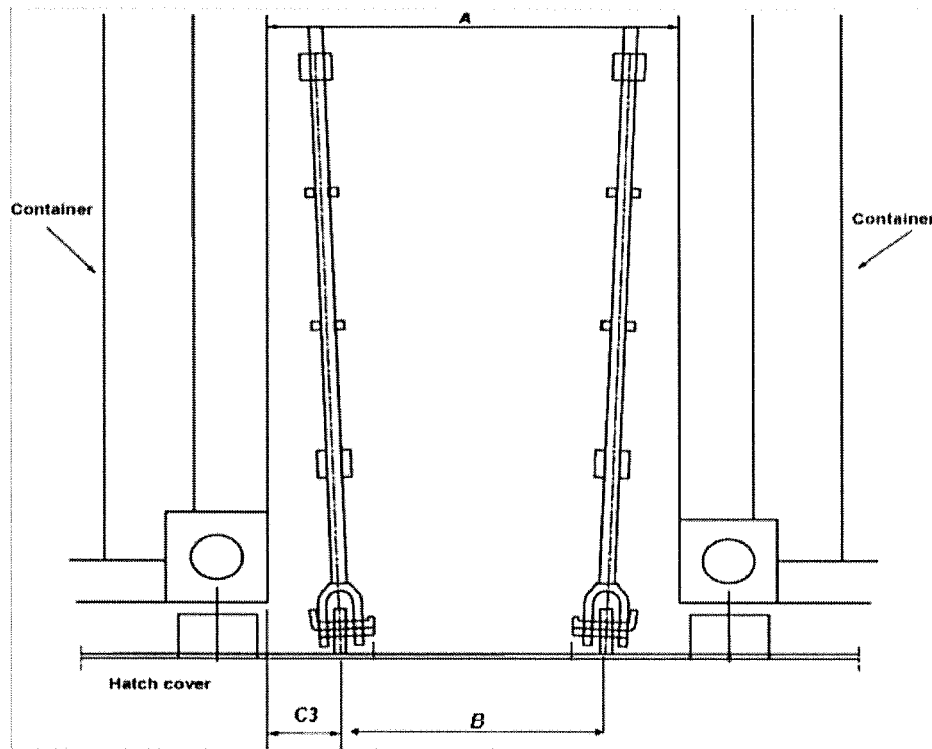

Figure 2

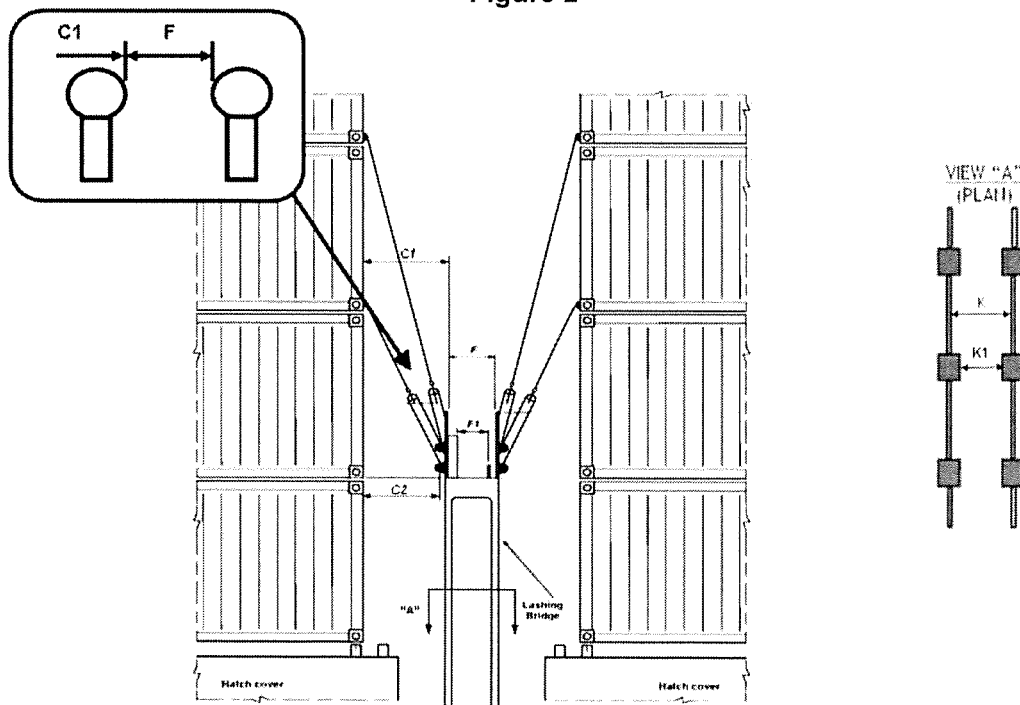

Figure 3

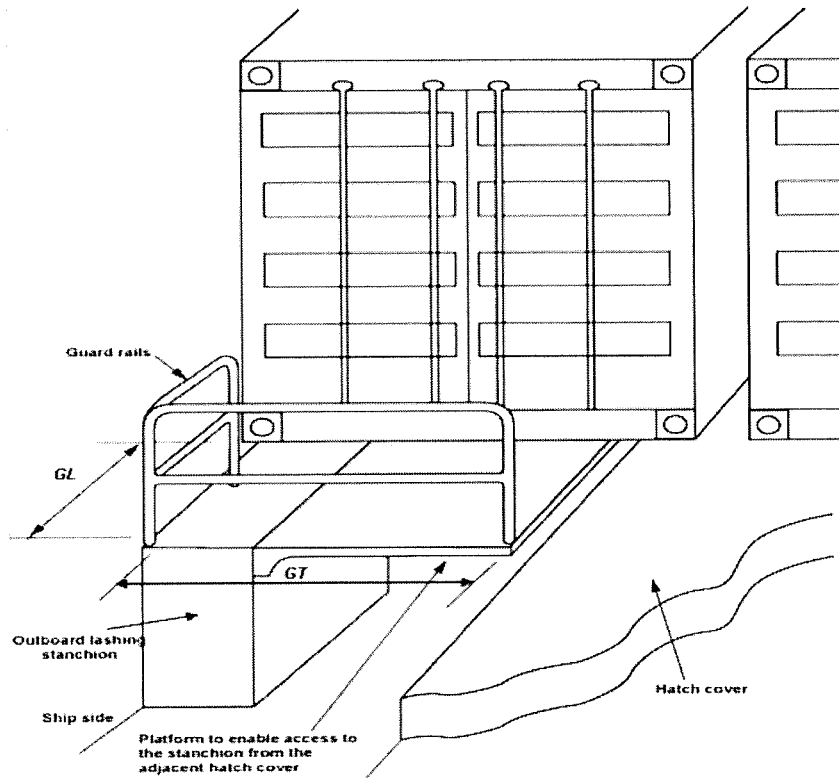
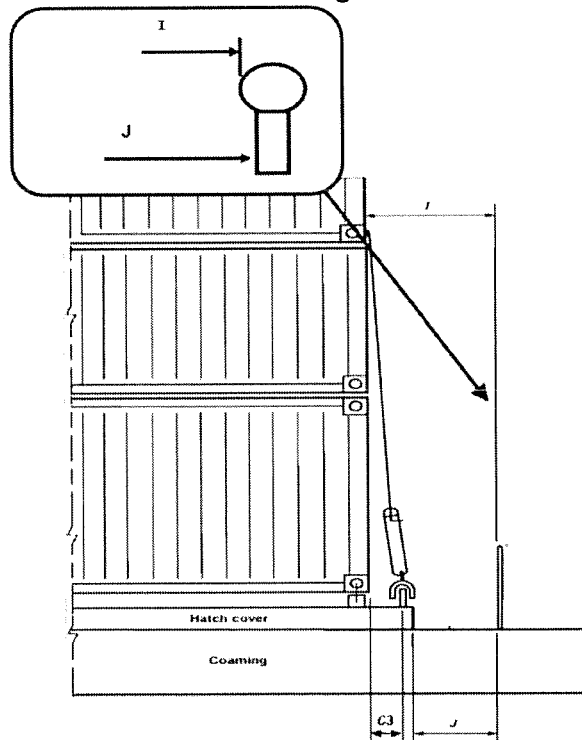

Figure 4





4 ALBERT EMBANKMENT
LONDON SE1 7SR
Telephone: +44 (0)20 7735 7611 Fax: +44 (0)20 7587 3210

Ref. T3/1.02

MSC.1/Circ.1352
30 June 2010

**AMENDMENTS TO THE CODE OF SAFE PRACTICE FOR CARGO STOWAGE
AND SECURING (CSS CODE)**

1 The Maritime Safety Committee, at its eighty-seventh session (12 to 21 May 2010), approved amendments to the Code of Safe Practice for Cargo Stowage and Securing (CSS Code), set out in the annex.

2 Member Governments are invited to bring the annexed Amendments to the CSS Code to the attention of shipowners, ship operators, shipmasters and crews and all other parties concerned and, in particular, encourage shipowners and terminal operators to:

- .1 apply the annexed amendments in its entirety for containerships, the keels of which were laid or which are at a similar stage of construction on or after 1 January 2015;
- .2 apply sections 4.4 (Training and familiarization), 7.1 (Introduction), 7.3 (Maintenance) and section 8 (Specialized container safety design) to existing containerships, the keels of which were laid or which are at a similar stage of construction before 1 January 2015; and
- .3 apply the principles of this guidance contained in sections 6 (Design) and 7.2 (Operational procedures) to existing containerships as far as practical by the flag State Administration with the understanding that existing ships would not be required to be enlarged or undergo other major structural modifications as determined.

ANNEX

**AMENDMENTS TO THE CODE OF SAFE PRACTICE FOR
CARGO STOWAGE AND SECURING (CSS CODE)**

- 1 The following new annex 14 is inserted after the existing annex 13:

"ANNEX 14

**GUIDANCE ON PROVIDING SAFE WORKING CONDITIONS
FOR SECURING OF CONTAINERS ON DECK**

1 AIM

To ensure that persons engaged in carrying out container securing operations on deck have safe working conditions and, in particular safe access, appropriate securing equipment and safe places of work. These guidelines should be taken into account at the design stage when securing systems are devised. These guidelines provide shipowners, ship builders, classification societies, Administrations and ship designers with guidance on producing or authorizing a Cargo Safe Access Plan (CSAP).

2 SCOPE

Ships which are specifically designed and fitted for the purpose of carrying containers on deck.

3 DEFINITIONS

3.1 *Administration* means the Government of the State whose flag the ship is entitled to fly.

3.2 *Fencing* is a generic term for guardrails, safety rails, safety barriers and similar structures that provide protection against the falls of persons.

3.3 *Lashing positions* include positions:

- .1 in between container stows on hatch covers;
- .2 at the end of hatches;
- .3 on outboard lashing stanchions/pedestals;
- .4 outboard lashing positions on hatch covers; and
- .5 any other position where people work with container securing.

3.4 *SATLs* are semi-automatic twistlocks.

3.5 *Securing* includes lashing and unlashings.

3.6 *Stringers* are the uprights or sides of a ladder.

3.7 *Turnbuckles and lashing rods** include similar cargo securing devices.

* Refer to standard ISO 3874, Annex D Lashing rod systems and tensioning devices.

4 GENERAL

4.1 Introduction

4.1.1 Injuries to dockworkers on board visiting ships account for the majority of accidents that occur within container ports, with the most common activity that involves such injuries being the lashing/unlashing of deck containers. Ships' crew engaged in securing operations face similar dangers.

4.1.2 During the design and construction of containerships the provision of a safe place of work for lashing personnel is essential.

4.1.3 Container shipowners and designers are reminded of the dangers associated with container securing operations and urged to develop and use container securing systems which are safe by design. The aim should be to eliminate or at least minimize the need for:

- .1 container top work;
- .2 work in other equally hazardous locations; and
- .3 the use of heavy and difficult to handle securing equipment.

4.1.4 It should be borne in mind that providing safe working conditions for securing containers deals with matters relating to design, operation, and maintenance, and that the problems on large containerships are not the same as on smaller ones.

4.2 Revised Recommendations on safety of personnel during container securing operations (MSC.1/Circ.1263)

Shipowners, ship designers and Administrations should take into account the recommendations on safe design of securing arrangements contained in these guidelines, and in the Recommendations on safety of personnel during container securing operations (MSC.1/Circ.1263).

4.3 Cargo Safe Access Plan (CSAP)

4.3.1 The Guidelines for the preparation of the Cargo Securing Manual (MSC/Circ.745) requires ships which are specifically designed and fitted for the purpose of carrying containers to have an approved Cargo Safe Access Plan (CSAP) on board, for all areas where containers are secured.

4.3.2 Stakeholders, including, but not limited to shipowners, ship designers, ship builders, administrations, classification societies and lashing equipment manufacturers, should be involved at an early stage in the design of securing arrangements on containerships and in the development of the CSAP.

4.3.3 The CSAP should be developed at the design stage in accordance with chapter 5 of the annex to MSC.1/Circ.1353.

4.3.4 Designers should incorporate the recommendations of this annex into the CSAP so that safe working conditions can be maintained during all anticipated configurations of container stowage.

4.4 Training and familiarization

4.4.1 Personnel engaged in cargo securing operations should be trained in the lashing and unlashings of containers as necessary to carry out their duties in a safe manner. This should include the different types of lashing equipment that are expected to be used.

4.4.2 Personnel engaged in cargo securing operations should be trained in the identification and handling of bad order or defective securing gear in accordance with each ship's procedures to ensure damaged gear is segregated for repair and maintenance or disposal.

4.4.3 Personnel engaged in cargo securing operations should be trained to develop the knowledge and mental and physical manual handling skills that they require to do their job safely and efficiently, and to develop general safety awareness to recognize and avoid potential dangers.

4.4.4 Personnel should be trained in safe systems of work. Where personnel are involved in working at heights, they should be trained in the use of relevant equipment. Where practical, the use of fall protection equipment should take precedence over fall arrest systems.

4.4.5 Personnel who are required to handle thermal cables and/or connect and disconnect temperature control units should be given training in recognizing defective cables, receptacles and plugs.

4.4.6 Personnel engaged in containership cargo operations should be familiarized with the ship's unique characteristics and potential hazards arising from such operations necessary to carry out their duties.

5 RESPONSIBILITIES OF INVOLVED PARTIES

5.1 Administrations should ensure that:

- .1 lashing plans contained within the approved Cargo Securing Manual are compatible with the current design of the ship and the intended container securing method is both safe and physically possible;
- .2 the Cargo Securing Manual, lashing plans and the CSAP are kept up to date; and
- .3 lashing plans and the CSAP are compatible with the design of the vessel and the equipment available.

5.2 Shipowners and operators should ensure that:

- .1 portable cargo securing devices are certified and assigned with a maximum securing load (MSL). The MSL should be documented in the cargo securing manual as required by the CSS Code;
- .2 the operational recommendations of this annex are complied with;

- .3 correction, changes or amendments of the Cargo Securing Manual, lashing plans and the Cargo Safe Access Plan (CSAP) should be promptly sent to the competent authority for approval; and
 - .4 only compatible and certified equipment in safe condition is used.
- 5.3 Designers should follow design recommendations of these guidelines.
- 5.4 Shipbuilders should follow design recommendations of these guidelines.
- 5.5 Containership terminal operators should ensure that the recommendations of relevant parts of this annex are complied with.

6 DESIGN

6.1 General design considerations

6.1.1 Risk assessment

6.1.1.1 Risk assessments should be performed at the design stage taking into account the recommendations of this annex to ensure that securing operations can be safely carried out in all anticipated container configurations. This assessment should be conducted with a view toward developing the Cargo Safe Access Plan (CSAP). Hazards to be assessed should include but not be limited to:

- .1 slips, trips and falls;
- .2 falls from height;
- .3 injuries whilst manually handling lashing gear;
- .4 being struck by falling lashing gear or other objects;
- .5 potential damage due to container operations. High-risk areas should be identified in order to develop appropriate protection or other methods of preventing significant damage;
- .6 adjacent electrical risks (temperature controlled unit cable connections, etc.);
- .7 the adequacy of the access to all areas that is necessary to safely perform container securing operations;
- .8 ergonomics (e.g., size and weight of equipment) of handling lashing equipment; and
- .9 implications of lashing 9'6" high, or higher, containers and mixed stows of 40' and 45' containers.

6.1.1.2 Shipbuilders should collaborate with designers of securing equipment in conducting risk assessments and ensure that the following basic criteria are adhered to when building containerships.

6.1.2 Ship designers should ensure that container securing operations performed in outer positions can be accomplished safely. As a minimum, a platform should be provided on which to work safely. This platform should have fencing to prevent workers falling off it.

6.1.3 The space provided between the containers stows for workers to carry out lashing operations should provide:

- .1 a firm and level working surface;
- .2 a working area, excluding lashings in place, to provide a clear sight of twist lock handles and allow for the manipulation of lashing gear;
- .3 sufficient spaces to permit the lashing gear and other equipment to be stowed without causing a tripping hazard;
- .4 sufficient spaces between the fixing points of the lashing bars on deck, or on the hatch covers, to tighten the turnbuckles;
- .5 access in the form of ladders on hatch coamings;
- .6 safe access to lashing platforms;
- .7 protective fencing on lashing platforms; and
- .8 adequate lighting in line with these guidelines.

6.1.4 Ship designers should aim to eliminate the need to access and work on the tops of deck stows.

6.1.5 Platforms should be designed to provide a clear work area, unencumbered by deck piping and other obstructions and take into consideration:

- .1 containers must be capable of being stowed within safe reach of the workers using the platform; and
- .2 the work area size and the size of the securing components used.

6.2 Provisions for safe access

6.2.1 General provisions

6.2.1.1 The minimum clearance for transit areas should be at least 2 m high and 600 mm wide.

6.2.1.2 All relevant deck surfaces used for movement about the ship and all passageways and stairs should have non-slip surfaces.

6.2.1.3 Where necessary for safety, walkways on deck should be delineated by painted lines or otherwise marked by pictorial signs.

6.2.1.4 All protrusions in access ways, such as cleats, ribs and brackets that may give rise to a trip hazard should be highlighted in a contrasting colour.

6.2.2 Lashing position design (platforms, bridges and other lashing positions)

6.2.2.1 Lashing positions should be designed to eliminate the use of three high lashing bars and be positioned in close proximity to lashing equipment stowage areas. Lashing positions should be designed to provide a clear work area which is unencumbered by deck piping and other obstructions and take into consideration:

- .1 the need for containers to be stowed within safe reach of the personnel using the lashing position so that the horizontal operating distance from the securing point to the container does not exceed 1,100 mm and not less than 220 mm for lashing bridges and 130 mm for other positions;
- .2 the size of the working area and the movement of lashing personnel; and
- .3 the length and weight of lashing gear and securing components used.

6.2.2.2 The width of the lashing positions should preferably be 1,000 mm, but not less than 750 mm.

6.2.2.3 The width of permanent lashing bridges should be:

- .1 750 mm between top rails of fencing; and
- .2 a clear minimum of 600 mm between storage racks, lashing cleats and any other obstruction.

6.2.2.4 Platforms on the end of hatches and outboard lashing stations should preferably be at the same level as the top of the hatch covers.

6.2.2.5 Toe boards (or kick plates) should be provided around the sides of elevated lashing bridges and platforms to prevent securing equipment from falling and injuring people. Toe boards should preferably be 150 mm high, however, where this is not possible they should be at least 100 mm high.

6.2.2.6 Any openings in the lashing positions through which people can fall should be possible to be closed.

6.2.2.7 Lashing positions should not contain obstructions, such as storage bins or guides to reposition hatch covers.

6.2.2.8 Lashing positions which contain removable sections should be capable of being temporarily secured.

6.2.3 Fencing design

6.2.3.1 Bridges and platforms, where appropriate, should be fenced. As a minimum, fencing design should take into consideration:

- .1 the strength and height of the rails should be designed to prevent workers from falling;

- .2 flexibility in positioning the fencing of gaps. A horizontal unfenced gap should not be greater than 300 mm;
- .3 provisions for locking and removal of fencing as operational situations change based on stowage anticipated for that area;
- .4 damage to fencing and how to prevent failure due to that damage; and
- .5 adequate strength of any temporary fittings. These should be capable of being safely and securely installed.

6.2.3.2 The top rail of fencing should be 1 m high from the base, with two intermediate rails. The opening below the lowest course of the guard rails should not exceed 230 mm. The other courses should be not more than 380 mm apart.

6.2.3.3 Where possible fences and handrails should be highlighted with a contrasting colour to the background.

6.2.3.4 Athwartships cargo securing walkways should be protected by adequate fencing if an unguarded edge exists when the hatch cover is removed.

6.2.4 Ladder and manhole design

6.2.4.1 Where a fixed ladder gives access to the outside of a lashing position, the stringers should be connected at their extremities to the guardrails of the lashing position, irrespective of whether the ladder is sloping or vertical.

6.2.4.2 Where a fixed ladder gives access to a lashing position through an opening in the platform, the opening shall be protected with either a fixed grate with a lock back mechanism, which can be closed after access, or fencing. Grabrails should be provided to ensure safe access through the opening.

6.2.4.3 Where a fixed ladder gives access to a lashing position from the outside of the platform, the stringers of the ladder should be opened above the platform level to give a clear width of 700 to 750 mm to enable a person to pass through the stringers.

6.2.4.4 A fixed ladder should not slope at an angle greater than 25° from the vertical. Where the slope of a ladder exceeds 15° from the vertical, the ladder should be provided with suitable handrails not less than 540 mm apart, measured horizontally.

6.2.4.5 A fixed vertical ladder of a height exceeding 3 m, and any fixed vertical ladder, from which a person may fall into a hold, should be fitted with guard hoops, which should be constructed in accordance with paragraphs 6.2.4.6 and 6.2.4.7.

6.2.4.6 The ladder hoops should be uniformly spaced at intervals not exceeding 900 mm and should have a clearance of 750 mm from the rung to the back of the hoop and be connected by longitudinal strips secured to the inside of the hoops, each equally spaced round the circumference of the hoop.

6.2.4.7 The stringers should be carried above the floor level of the platform by at least 1 m and the ends of the stringers should be given lateral support and the top step or rung should be level with the floor of the platform unless the steps or rungs are fitted to the ends of the stringers.

6.2.4.8 As far as practicable, access ladders and walkways, and work platforms should be designed so that workers do not have to climb over piping or work in areas with permanent obstructions.

6.2.4.9 There should be no unprotected openings in any part of the workplace. Access opening must be protected with handrails or access covers that can be locked back during access.

6.2.4.10 As far as practicable, manholes should not be situated in transit areas, however, if they are, proper fencing should protect them.

6.2.4.11 Access ladders and manholes should be large enough for persons to safely enter and leave.

6.2.4.12 A foothold at least 150 mm deep should be provided.

6.2.4.13 Handholds should be provided at the top of the ladder to enable safe access to the platform to be gained.

6.2.4.14 Manhole openings that may present a fall hazard should be highlighted in contrasting colour around the rim of the opening.

6.2.4.15 Manhole openings at different levels of the lashing bridge should not be located directly below one another, as far as practicable.

6.3 Lashing systems

6.3.1 General provisions

Lashing systems, including tensioning devices, should:

- .1 conform to international standards*, where applicable;
- .2 be compatible with the planned container stowages;
- .3 be compatible with the physical ability of persons to safely hold, deploy and use such equipment;
- .4 be uniform and compatible, e.g., twistlocks and lashing rod heads should not interfere with each other;
- .5 be subject to a periodic inspection and maintenance regime. Non-conforming items should be segregated for repair or disposal; and
- .6 be according to the CSM.

6.3.2 Twistlock design

6.3.2.1 Shipowners should ensure that the number of different types of twistlocks provided for cargo securing is kept to a minimum and clear instructions are provided for their operation. The use of too many different types of twistlocks may lead to confusion as to whether the twistlocks are locked.

* Refer to standard ISO 3874 – The Handling and Securing of Type 1 Freight Containers, annex A-D.

6.3.2.2 The design of twistlocks should ensure the following:

- .1 positive locking with easy up and down side identification;
- .2 dislodging from corner fitting is not possible even when grazing a surface;
- .3 access and visibility of the unlocking device is effective in operational situations;
- .4 unlocked positions are easily identifiable and do not relock inadvertently due to jolting or vibration; and
- .5 unlocking poles are as light as possible, of a simple design for ease of use.

6.3.2.3 Where it is not feasible to entirely eliminate working on the tops of container stows, the twistlock designs used should minimize the need for such working, e.g., use of SATLs, fully automatic twistlocks or similar design.

6.3.3 Lashing rod design

6.3.3.1 The design of containership securing systems should take into account the practical abilities of the workers to lift, reach, hold, control and connect the components called for in all situations anticipated in the cargo securing plan.

6.3.3.2 The maximum length of a lashing rod should be sufficient to reach the bottom corner fitting of a container on top of two high cube containers and be used in accordance with the instructions provided by the manufacturers.

6.3.3.3 The weight of lashing rods should be minimized as low as possible consistent with the necessary mechanical strength.

6.3.3.4 The head of the lashing rod that is inserted in the corner fitting should be designed with a pivot/hinge or other appropriate device so that the rod does not come out of the corner fitting accidentally.

6.3.3.5 The rod's length in conjunction with the length and design of the turnbuckle should be such that the need of extensions is eliminated when lashing high cube (9'6") containers.

6.3.3.6 Lightweight rods should be provided where special tools are needed to lash high cube containers.

6.3.4 Turnbuckle design

6.3.4.1 Turnbuckle end fittings should be designed to harmonize with the design of lashing rods.

6.3.4.2 Turnbuckles should be designed to minimize the work in operating them.

6.3.4.3 Anchor points for turnbuckles should be positioned to provide safe handling and to prevent the bending of rods.

6.3.4.4 To prevent hand injury during tightening or loosening motions, there should be a minimum distance of 70 mm between turnbuckles.

6.3.4.5 The turnbuckle should incorporate a locking mechanism which will ensure that the lashing does not work loose during the voyage.

6.3.4.6 The weight of turnbuckles should be minimized as low as possible consistent with the necessary mechanical strength.

6.3.5 Storage bins and lashing equipment stowage design

6.3.5.1 Bins or stowage places for lashing materials should be provided.

6.3.5.2 All lashing gear should be stowed as close to its intended place of use as possible.

6.3.5.3 The stowage of securing devices should be arranged so they can easily be retrieved from their stowage location.

6.3.5.4 Bins for faulty or damaged gear should also be provided and appropriately marked.

6.3.5.5 Bins should be of sufficient strength.

6.3.5.6 Bins and their carriers should be designed to be lifted off the vessel and restowed.

6.4 Lighting design

A lighting plan should be developed to provide for:

- .1 the proper illumination of access ways, not less than 10 lux (1 foot candle)^{*}, taking into account the shadows created by containers that may be stowed in the area to be lit, for example different length containers in or over the work area;
- .2 a separate fixed or temporary (where necessary) lighting system for each working space between the container bays, which is bright enough, not less than 50 lux (5 foot candle)^{*}, for the work to be done, but minimizes glare to the deck workers;
- .3 such illumination should, where possible, be designed as a permanent installation and adequately guarded against breakage; and
- .4 the illumination intensity should take into consideration the distance to the uppermost reaches where cargo securing equipment is utilized.

^{*} Refer to Safety and Health in Ports, ILO Code of Practice, section 7.1.5.

7 OPERATIONAL AND MAINTENANCE PROCEDURES

7.1 Introduction

7.1.1 Procedures for safe lashing and securing operations should be included in the ship's Safety Management System as part of the ISM Code documentation.

7.1.2 Upon arrival of the ship, a safety assessment of the lashing positions and the access to those positions should be made before securing work commences.

7.2 Operational procedures

7.2.1 *Container deck working*

7.2.1.1 Transit areas should be safe and clear of cargo and all equipment.

7.2.1.2 Openings that are necessary for the operation of the ship, which are not protected by fencing, should be closed during cargo securing work. Any necessarily unprotected openings in work platforms (i.e. those with a potential fall of less than 2 m), and gaps and apertures on deck should be properly highlighted.

7.2.1.3 The use of fencing is essential to prevent falls. When openings in safety barriers are necessary to allow container crane movements, particularly with derricking cranes, removable fencing should be used whenever possible.

7.2.1.4 It should be taken into account that when lifting lashing bars that can weigh between 11 and 21 kg and turnbuckles between 16 and 23 kg, there may be a risk of injury and severe illness as a result of physical strain if handled above shoulder height with the arms extended. It is therefore recommended that personnel work in pairs to reduce the individual workload in securing the lashing gear.

7.2.1.5 The company involved with cargo operation should anticipate, identify, evaluate and control hazards and take appropriate measures to eliminate or minimize potential hazards to prevent in particular with harmful lumbar spinal damage and severe illness as a result of physical strain.

7.2.1.6 Personnel engaged in containership cargo operations should wear appropriate Personnel Protective Equipment (PPE) whilst carrying out lashing operations. The PPE should be provided by the company.

7.2.1.7 Manual twistlocks should only be used where safe access is provided.

7.2.1.8 Containers should not be stowed in spaces configured for larger sized containers unless they can be secured under safe working conditions.

7.2.2 *Container top working*

7.2.2.1 When work on container tops can not be avoided, safe means of access should be provided by the container cargo operation terminal, unless the ship has appropriate means of access in accordance with the CSAP.

7.2.2.2 Recommended practice involves the use of a safety cage lifted by a spreader to minimize the risk to personnel.

7.2.2.3 A safe method of work should be developed and implemented to ensure the safety of lashers when on the top of container stows on deck. Where practical, the use of fall prevention equipment should take precedence over fall arrest equipment.

7.2.3 Failure to provide safe lashing stations on board/carry out lashing by port workers

7.2.3.1 Where there are lashing and unlashings locations on board ship where no fall protection, such as adequate handrails are provided, and no other safe method can be found, the containers should not be lashed or unlashings and the situation should be reported to shoreside supervisor and the master or deck officer immediately.

7.2.3.2 If protective systems cannot be designed to provide safe protected access and lashing work positions, in all cargo configurations then cargo should not be stowed in that location. Neither crew nor shore workers should be subjected to hazardous working conditions in the normal course of securing cargo.

7.3 Maintenance

7.3.1 In line with section 2.3 (Inspection and maintenance schemes) of the Revised Guidelines for the preparation of the cargo securing manual (MSC.1/Circ.1353) all ships should maintain a record book, which should contain the procedures for accepting, maintaining and repairing or rejecting of cargo securing devices. The record book should also contain a record of inspections.

7.3.2 Lighting should be properly maintained.

7.3.3 Walkways, ladders, stairways and fencings should be subject to a periodic maintenance programme which will reduce/prevent corrosion and prevent subsequent collapse.

7.3.4 Corroded walkways, ladders, stairways and fencings should be repaired or replaced as soon as practicable. The repairs should be effected immediately if the corrosion could prevent safe operations.

7.3.5 It should be borne in mind that turnbuckles covered with grease are difficult to handle when tightening.

7.3.6 Storage bins and their carriers should be maintained in a safe condition.

8 SPECIALIZED CONTAINER SAFETY DESIGN

8.1 Temperature controlled unit power outlets should provide a safe, watertight electrical connection.

8.2 Temperature controlled unit power outlets should feature a heavy duty, interlocked and circuit breaker protected electrical power outlet. This should ensure the outlet can not be switched "live" until a plug is fully engaged and the actuator rod is pushed to the "On" position. Pulling the actuator rod to the "Off" position should manually de-energize the circuit.

8.3 The temperature controlled unit power circuit should de-energize automatically if the plug is accidentally withdrawn while in the "On" position. Also, the interlock mechanism should break the circuit while the pin and sleeve contacts are still engaged.

This provides total operator safety and protection against shock hazard while eliminating arcing damage to the plug and receptacle.

8.4 Temperature controlled unit power outlets should be designed to ensure that the worker is not standing directly in front of the socket when switching takes place.

8.5 The positioning of the temperature controlled unit feed outlets should not be such that the flexible cabling needs to be laid out in such a way as to cause a tripping hazard.

8.6 Stevedores or ship's crew who are required to handle temperature controlled unit cables and/or connect and disconnect reefer units should be given training in recognizing defective wires and plugs.

8.7 Means or provisions should be provided to lay the temperature controlled unit cables in and protect them from lashing equipment falling on them during lashing operations.

8.8 Defective or inoperative temperature controlled unit plugs/electrical banks should be identified and confirmed as "locked out/tagged out" by the vessel.

9 REFERENCES

ILO Code of Practice – Safety and Health in Ports

ILO Convention 152 – Occupational Safety and Health in Dock Work

ISO Standard 3874 – The Handling and Securing of Type 1 Freight Containers

International Convention on Load Lines, 1966, as modified by the 1988 LL Protocol

Revised Recommendation on safety of personnel during container securing operations (MSC.1/Circ.1263)

Revised Guidelines for the preparation of the Cargo Securing Manual (MSC.1/Circ.1353)."